

**Lecture Notes on  
ENERGY CONVERSION - II**



**5TH SEMESTER DIPLOMA  
SUBJECT CODE: TH-2**



**PREPARED BY:**

**PRIYABRATA PALASINGH NAYAK**

**GOVERNMENT POLYTECHNIC, KENDRAPARA  
Department of Electrical Engineering  
Derabishi, Odisha 754289  
[www.gpkendrapara.org](http://www.gpkendrapara.org)**

## ENERGY CONVERSION – II

|                 |         |                           |     |
|-----------------|---------|---------------------------|-----|
| Course code:    | EET 501 | Semester                  | 5th |
| Total Period:   | 75      | Examination               | 3   |
| Theory periods: | 4P/week | Class Test:               | hrs |
| Tutorial:       | 1 P/W   | Teacher's Assessment:     | 20  |
| Maximum marks:  | 100     | End Semester Examination: | 10  |
|                 |         |                           | 70  |

### A. Rationale:

Modern industries are mostly equipped with AC machines. So the diploma students of fifth semester are given a scope to gain the concepts of electrical machines like synchronous generators, synchronous Motors, induction motors, single phase induction motors and fractional horse power motors and other special machines. The students are required to be familiar with constructional features, working principles, starting and speed control methods and performance characteristics with applications of the machines. Numerical solving makes the student to understand the feature more clearly. So some numerical are to be solved wherever applicable.

### B. Objectives:

1. To describe various parts, their material specification with suitable reasoning and working principle of induction motors, synchronous motor, synchronous generators, single phase AC motors and fractional horse power and other special machines.
2. To describe their operating principle and working characteristics, derive torque equation of three phase motors.
3. To describe the losses and efficiency of all three phase machine like induction motor, synchronous motor, synchronous generator.
4. To describe methods of starting and speed control of AC motors.
5. To workout problems on synchronous generator and motor, 3-phase induction motor.
6. To describe different test on such three phase machine.

### C. TOPIC WISE DISTRIBUTION OF PERIODS

| Sl. No. | Topics                       | Periods   |
|---------|------------------------------|-----------|
| 1.      | Induction motor              | 14        |
| 2.      | Alternator                   | 14        |
| 3.      | Synchronous Motor            | 08        |
| 4.      | Single Phase induction motor | 08        |
| 5.      | AC commutator motors         | 06        |
| 6.      | Special Electric Machine     | 05        |
| 7.      | Three phase transformers     | 05        |
|         | <b>Total</b>                 | <b>60</b> |

## **D. COURSE CONTENT:**

- 1. THREEPHASEINDUCTION MOTOR 14**
1. Explain and derive production of rotating magnetic field.
  1. Explain constructional feature of Squirrel cage and Slip ring induction motors.
  2. Explain principles of operation of 3-phase Induction motor.
  1. Explain slip speed, slip and slip relation with rotor quantities.
  3. Derive Torque during starting and running and conditions for maximum torque. (solve numerical problems)
  1. Derive Torque-slip characteristics.
  4. Derive relation between full load torque and starting torque etc. (solve numerical problems)
  5. Determine the relations between Rotor Copper loss, Rotor output and Gross Torque, and relationship of slip with rotor copper loss. (solve numerical problems)
  1. 9 Explain and state Methods of starting and different types of starters.
  1. 10 Explain speed control by Voltage Control, Rotor resistance control, pole changing, frequency control methods.
  1. 11 Describe plugging applicable to three phase induction motor.
  1. 12 Describe different types of motor enclosures.
  1. 13 Explain principle of Induction Generator and state its applications.
- 2. ALTERNATOR 14**
- State types of alternator and their constructional features.  
Explain working principle of alternator and establish the relation between speed and frequency  
Explain terminology in armature winding, and derive expressions for winding factors (Pitch factor, Distribution factor)  
Explain harmonics, its causes and impact on winding factor.  
Derive E.M.F equation. (Solve numerical problems)  
Explain Armature reaction and its effect on emf at different pf of load.  
Draw the vector diagram of loaded alternator. (Solve numerical problems)  
State and explain testing of alternator (open circuit and short circuit methods) (Solve numerical problems)  
Determination of voltage regulation of Alternator by direct loading and synchronous impedance method.  
Explain parallel operation of alternator using synchro-scope, dark and bright lamp method.  
Explain distribution of load by parallel connected alternators.
- 3. SYNCHRONOUS MOTOR 08**
- Explain constructional feature of Synchronous Motor.  
Explain principles of operation, concept of load angle.  
Explain effect of varying load with constant excitation. Explain effect of varying excitation with constant load. Derive torque, power developed  
Explain power angle characteristics of cylindrical rotor motor.  
Explain effect of excitation on Armature current and power factor.  
Explain Hunting & function of Damper Bars.  
Describe method of starting of Synchronous motor.  
State application of synchronous motor.

- 4. SINGLE PHASE INDUCTION MOTOR** **08**  
 Explain Rotating – field theory of 1-phase induction motor.  
 Explain Ferrari's principle.  
 Explain Working principle, Torque speed characteristics, performance characteristics and application of following single phase motors.  
 Split phase motor.  
 Capacitor Start motor.  
 Capacitor start, capacitor run motor  
 Permanent capacitor type motor  
 Shaded pole motor.  
 Explain the method to change the direction of rotation of above motors
- 5. COMMUTATOR MOTORS** **06**  
 Explain construction, working principle, running characteristic and application of single phase series motor.  
 Explain construction, working principle and application of Universal motors.  
 Explain working principle of Repulsion start Motor, Repulsion start Induction run motor, Repulsion Induction motor.
- 6. SPECIAL ELECTRICAL MACHINE** **05**  
 Principle of Stepper motor.  
 Classification of Stepper motor.  
 Principle of variable reluctant stepper motor.  
 Principle of Permanent magnet stepper motor.  
 Principle of hybrid stepper motor.  
 Applications of Stepper motor.
- 7. THREE PHASE TRANSFORMERS** **05**  
 Explain Grouping of winding, Advantages.  
 Explain parallel operation of the three phase transformers.  
 Explain tap changer (On/Off load tap changing)  
 State maintenance of Transformers.

**Learning Resources:**

| Sl.No | Name of Authors          | Title of the Book                            | Name of the publisher |
|-------|--------------------------|--|-----------------------|
| 1     | B L Theraja, A K Theraja | A text book of Electrical Technology Part-II | S Chand               |
| 2     | Asfaq Husain             | Electrical Machine                           | Dhanpat Rai and Sons  |
| 3     | J B Gupta                | Electrical Machines                          | S K Kataria and Sons  |
| 4     | D P Kothari, I J Nagrath | Electric Machines                            | Mc Graw Hill          |
| 5     | S K Bhattacharya         | Electric Machines                            | Mc Graw Hill          |

## THREE PHASE INDUCTION MOTOR

### Explain and derive production of rotating magnetic field.

A rotating magnetic field is a magnetic field that has moving polarities in which its opposite poles rotate about a central point or axis. ... Rotating magnetic fields are often utilized for electromechanical applications such as induction motors and electric generators

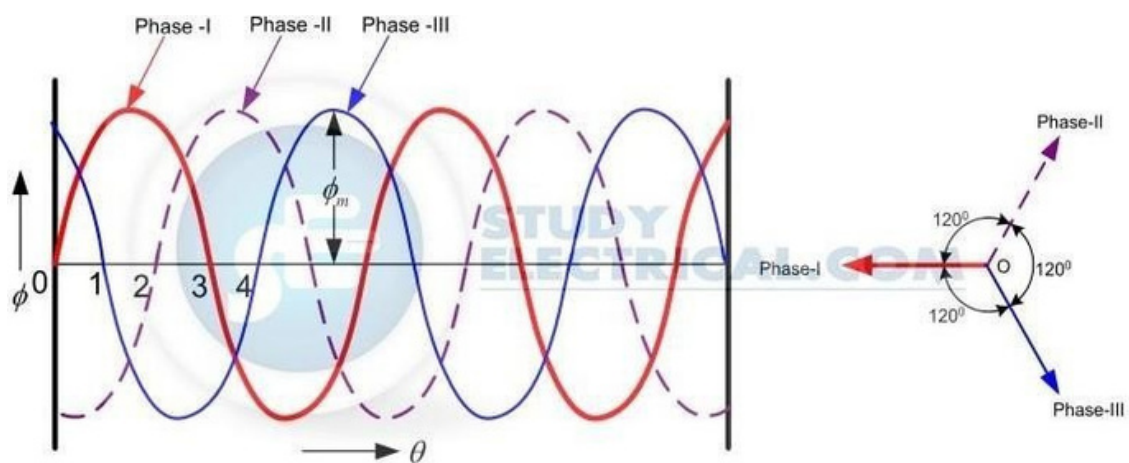

When a 3-phase winding is energized from a 3-phase supply, a rotating magnetic field is produced. This field is such that its poles do not remain in a fixed position on the stator but go on shifting their positions around the stator. For this reason, it is called a rotating field.

It can be shown that the magnitude of this rotating field is constant and is equal to  $1.5 \phi_m$  where  $\phi_m$  is the maximum flux due to any phase.

A three-phase induction motor consists of three phase winding as its stationary part called stator. The three-phase stator winding is connected in star or delta.

The three-phase windings are displaced from each other by 120°. The windings are supplied by a balanced three phase ac supply. The three-phase currents flow simultaneously through the windings and are displaced from each other by 120° electrical. Each alternating phase current produces its own flux which is sinusoidal.

So all three fluxes are sinusoidal and are separated from each other by 120°.

If the phase sequence of the windings is R-Y-B, then

mathematical equations for the instantaneous values of the three fluxes  $\phi_R$ ,  $\phi_Y$ ,  $\phi_B$  can be written as,

$$\phi_R = \phi_m \sin(\omega t)$$

$$\phi_Y = \phi_m \sin(\omega t -$$

$$120)$$

$$\phi_B = \phi_m \sin(\omega t - 240)$$

As windings are identical and supply is balanced, the magnitude of each flux is  $\phi_m$ .

**Case 1 :  $\omega t = 0$**

$$\phi_R = \phi_m \sin(0) = 0$$

$$\phi_Y = \phi_m \sin(0 - 120) = -$$

$$0.866 \phi_m$$

$$\phi_B = \phi_m \sin(0 - 240) = +0.866 \phi_m$$

**Case 2 :  $\omega t = 60$**

$$\phi_R = \phi_m \sin(60) =$$

$$+0.866 \phi_m$$

$$\phi_Y = \phi_m \sin(-60) = -0.866 \phi_m$$

$$\phi_B = \phi_m \sin(-180) = 0$$

Case 3 :  $\omega t = 120$

$$\phi_R = \phi_m \sin(120) = +0.866 \phi_m$$

$$\phi = \phi_m \sin(0) = 0$$

$$\phi_Y = \phi_m \sin(-120) = -0.866 \phi_m$$

$\phi$

B

Case 4 :  $\omega t = 180$

$$\phi_R = \phi_m \sin(180) = 0$$

$$\phi_Y = \phi_m \sin(60) =$$

$$+0.866 \phi_m$$

$$\phi_B = \phi_m \sin(-60) = -0.866 \phi_m$$

When  $\theta = 0^\circ$   
(At point 0)

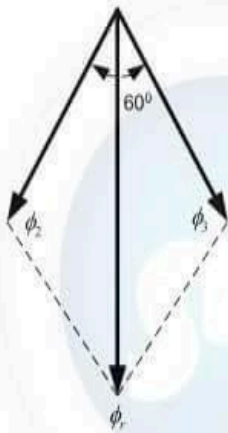

$$\begin{aligned} \phi_1 &= 0 \\ \phi_2 &= -\frac{\sqrt{3}}{2} \phi_m \\ \phi_3 &= \frac{\sqrt{3}}{2} \phi_m \end{aligned}$$

When  $\theta = 60^\circ$   
(At point 1)

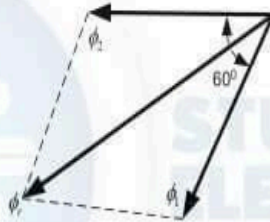

$$\begin{aligned} \phi_1 &= \frac{\sqrt{3}}{2} \phi_m \\ \phi_2 &= -\frac{\sqrt{3}}{2} \phi_m \\ \phi_3 &= 0 \end{aligned}$$

When  $\theta = 120^\circ$   
(At point 2)

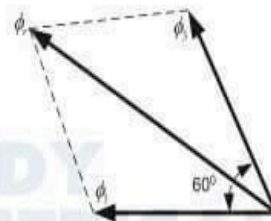

$$\begin{aligned} \phi_1 &= \frac{\sqrt{3}}{2} \phi_m \\ \phi_2 &= 0 \\ \phi_3 &= -\frac{\sqrt{3}}{2} \phi_m \end{aligned}$$

When  $\theta = 180^\circ$   
(At point 3)



$$\begin{aligned} \phi_1 &= 0 \\ \phi_2 &= \frac{\sqrt{3}}{2} \phi_m \\ \phi_3 &= -\frac{\sqrt{3}}{2} \phi_m \end{aligned}$$

## Explain constructional feature of Squirrel cage and Slip ring Induction motors.

### Construction Of Squirrel Cage Induction Motor

Any Induction Motor has a Stator and a Rotor. The construction of Stator for any induction motor is almost the same. But the rotor construction differs with respect to the type which is specified above.

#### ***Stator:***

The stator is the outer most component in the motor which can be seen. It may be constructed for single phase, three phase or even poly phase motors. But basically only the windings on the stator vary, not the basic layout of the stator. It is almost same for any given synchronous motor or a generator. It is made up of number of stampings, which are slotted to receive the windings. Lets see the construction of a three phase stator. The three phase windings are placed on the slots of laminated core and these windings are electrically spaced 120 degrees apart. These windings are connected as either star or delta depending upon the requirement. The leads are taken out usually three in number, brought out to the terminal box mounted on the motor frame. The insulation between the windings are generally varnish or oxide coated.

### *The Rotor: Squirrel Cage Rotor:*

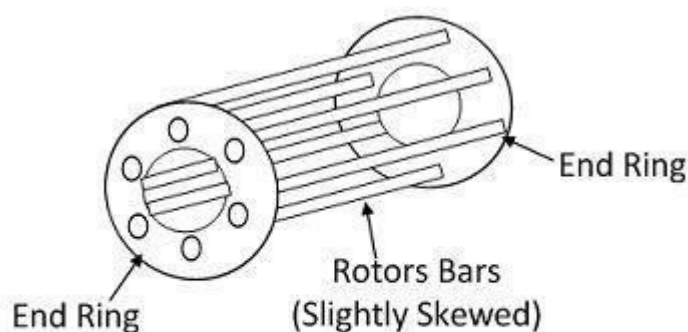

**Squirrel Cage Motor**

Circuit Globe

This kind of rotor consists of a cylindrical laminated core with parallel slots for carrying the rotor conductors, which are not wires, as we think, but thick, heavy bars of copper or aluminium (aluminium) or its alloys. The conductor bars are inserted from one end of the rotor and as one bar in each slot. There are end rings which are welded or electrically braced or even bolted at both ends of the rotor, thus maintaining electrical continuity. These end rings are short-circuited, after which they give a beautiful look similar to a squirrel thus the name.

One important point to be noted is that the end rings and the rotor conducting bars are permanently short-circuited, thus it is not possible to add any external resistance in series with the rotor circuit for starting purpose. The rotor conducting bars are usually not parallel to the shaft, but are purposely given slight skew. In small motors, the rotor is fabricated in a different way. The entire rotor core is placed in a mould and the rotor bars & end-rings are cast into one piece. The metal commonly used is aluminium alloy. Some very small rotors which operate on the basis of eddy current, have their rotor as solid steel without

any conductors.

## Slip Ring Induction Motor

Slip ring induction motor is one of the types of 3-phase induction motor and is a wound rotor motor type. Because of various advantages like low initial current, high starting torque, and improved power factor, it is used in applications that require high torque, cranes, and elevators. The rotor windings consist of more number of windings, higher induced voltage, and less current compared to the squirrel-cage rotor. The windings are connected to external resistance through slip rings, which helps to control the torque/speed of a motor.

In this type of three phase induction motor the rotor is wound for the same number of poles as that of the stator, but it has less number of slots and has fewer turns per phase of a heavier conductor. The rotor also carries star or delta winding similar to that of the stator winding.

The rotor consists of numbers of slots and rotor winding are placed inside these slots. The three end terminals are connected together to form a star connection. As its name indicates, three phase slip ring induction motor consists of slip rings connected on the same shaft as that of the rotor.

The three ends of three-phase windings are permanently connected to these slip rings. The external resistance can be easily connected through the brushes and slip rings and hence used for speed controlling and improving the starting [torque of three phase induction motor](#). The brushes are used to carry [current](#) to and from the rotor winding. These brushes are further connected to three phase star connected resistances. An electrical diagram of a slip ring three phase induction motor is shown below:

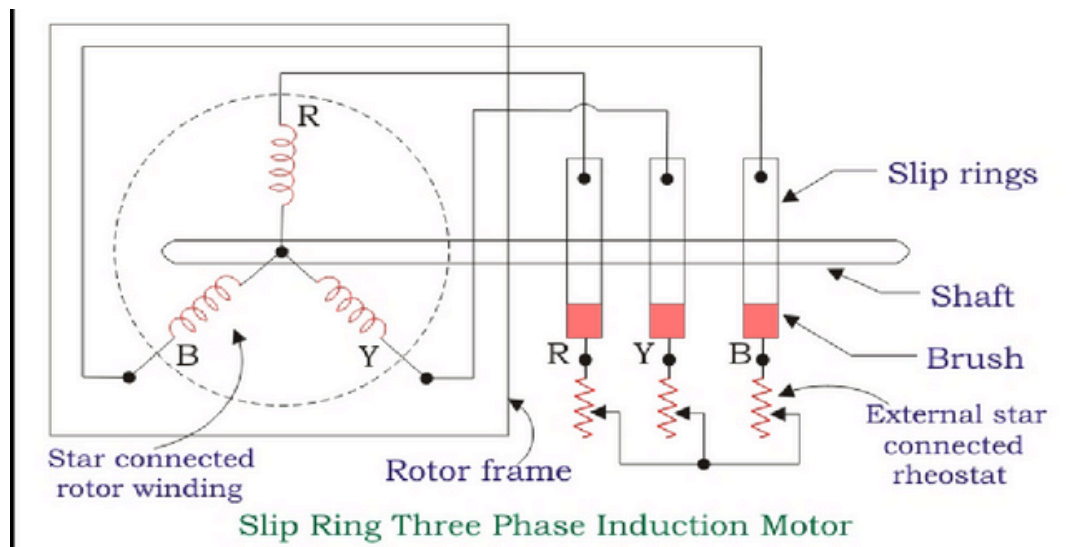

At starting, the resistance is connected to the rotor circuit and is gradually cut out as the rotor pick up its speed. When the motor is running the slip ring are shorted by connecting a metal collar, which connects all slip ring together, and the brushes are also removed. This reduces the wear and tear of the brushes. Due to the presence of slip rings and brushes the rotor construction becomes somewhat complicated therefore it is less used as compare to squirrel cage induction motor.

## 1. 3 Explain principles of operation of 3-phase Induction motor.

The stator of the motor consists of overlapping winding offset by an electrical angle of  $120^\circ$ . When we connect the primary winding, or the stator to a 3 phase AC source, it establishes rotating magnetic field which rotates at the synchronous speed. According to Faraday's law an emf induced in any circuit is due to the rate of change of magnetic flux linkage through the circuit. As the rotor winding in an induction motor are either closed through an external resistance or directly shorted by end ring, and cut the stator rotating magnetic field, an emf is induced in the rotor copper bar and due to this emf a current flows through the rotor conductor.

Here the relative speed between the rotating flux and static rotor conductor is the cause of current generation; hence as per Lenz's law, the rotor will rotate in the same direction to reduce the cause, i.e., the relative velocity.

Thus from the **working principle of three phase induction motor**, it may be observed that the rotor speed should not reach the synchronous speed produced by the stator. If the speeds become equal, there would be no such relative speed, so no emf induced in the rotor, and no current would be flowing, and therefore no torque would be generated.

Consequently, the rotor cannot reach the synchronous speed. The difference between the stator (synchronous speed) and rotor speeds is called the slip. The rotation of the magnetic field in an induction motor has the advantage that no electrical connections need to be made to the rotor.

Thus the **three phase induction motor** is:

- Self-starting.

- Less armature reaction and brush sparking because of the absence of commutators and brushes that may cause sparks.
- Robust in construction.
- Economical.
- Easier to maintain.

## 1. 4 Explain slip speed, slip and slip relation with rotor quantities.

### Slip Speed in an Induction Motor

**Definition:** The slip in an induction motor is the difference between the main flux speed and their rotor speed. The symbol  $S$  represents the slip. It is expressed by the percentage of synchronous speed. Mathematically, it is written as

$$\%S = \frac{N_s - N}{N_s} \times 100$$

The value of slip at full load varies from 6% in case of small motor and 2% in the large motor.

The induction motor never runs at synchronous speed. The speed of the rotor is always less than that of the synchronous speed. If the speed of the rotor is equal to the synchronous speed, no relative motion occurs between the stationary rotor conductors and the main field.

The no EMF induces in the rotor and zero current generates on the rotor conductors. The electromagnetic torque is also not induced. Thus, the speed of the rotor is always kept slightly less than the synchronous speed. The speed at which the induction motor work is known as the slip speed.

**The difference between the synchronous speed and the actual speed of the rotor is known as the slip speed. In other words, the slip speed shows the relative speed of the rotor concerning the speed of the field.**

The speed of the rotor is slightly less than the synchronous speed. Thus, the slip speed expresses the speed of the rotor relative to the field.

If  $N_s$  is the synchronous speed in revolution per minute

- $N_r$  is the actual rotor speed in revolution
- per minute. The slip speed of the

induction motor is given as

$$S = N_s - N_r \dots \dots \dots (1)$$

The fraction part of the synchronous speed is called the **Per Unit Slip** or **Fractional Slip**. The per unit slip is called the **Slip**. It is denoted by  $s$ .

$$S = \frac{N_s - N_r}{N_s} \text{ per unit (p. u) } \dots \dots \dots (2)$$

$$\text{Percentage slip} = \frac{N_s - N_r}{N_s} \times 100 \dots \dots \dots (3)$$

Therefore, the rotor speed is given by the equation shown below.

$$N_r = N_s (1 - S)$$

Alternatively, if

- $n_s$  is the synchronous speed in revolution per second
- $n_r$  is the actual rotor speed in revolution per second. Then,

$$S = \frac{n_s - n_r}{n_s} \text{ per unit (p. u) } \dots \dots \dots (4)$$

The percentage slip in revolution per second is given as shown below.

$$\text{Percentage slip} = \frac{n_s - n_r}{n_s} \times 100 \dots \dots (5)$$

Also,

$$s = \frac{\omega_s - \omega_r}{\omega_s} \dots \dots (5)$$

The slip of the induction motor varies from 5 percent for small motors to 2 percent for large motors.

### Importance of Slip

Slip plays an essential role in Induction motor. As we know, the slip speed is the difference between the synchronous and rotor speed of the induction motor. The emf induces in the rotor because of the relative motion, or we can say the slip speed of the motor. So,

$$e_2 \propto N_s - N_r$$

The rotor current is directly proportional to the induced emf.

$$i_2 \propto e_2$$

The torque is directly proportional to the rotor current.

$$T \propto i_2$$

Therefore,

$$T = K(N_s - N_r) \text{ or } T = KN_s \left( \frac{N_s - N_r}{N_s} \right) \text{ or } T = K_1 S$$

Hence, torque is directly proportional to slip.

$$T \propto S$$

The above equation shows that the torque induced on the rotor is directly proportional to the slip of the induction motor. The high value of slip induces the emf in the rotor. This EMF develops the heavy torque on the rotor conductors.

The value of the slip is adjusted by considering the load on the motor. For full-load, the high value of torque is required. This can be achieved by increasing the amount of the slip and reducing the speed of the rotor. The slip of the motor is kept low when the induction motor is running at no-load. The small slip produces the small torque on the motor.

The value of the induction motor slip is adjusted according to the requirement of the driving torque at the normal working condition.

**For the rotor side, the induced emf is affected by the slip (as the rotor gains speed, slip reduces and less emf is induced)**

## 1.5 Derive Torque during starting and running

and conditions for Maximum torque.

### Torque during running condition

The torque produced by [three phase induction motor](#) depends upon the following three factors:

Firstly the magnitude of rotor current, secondly the [flux](#) which interact with the rotor of three phase induction motor and is responsible for producing emf in the rotor part of [induction motor](#), lastly the [power factor](#) of rotor of the three phase induction motor.

Combining all these factors, we get the equation of torque as-

$$T \propto \phi I_2 \cos \theta_2$$

Where, T is the torque produced by the induction motor,  $\phi$  is flux responsible for producing induced emf,

$I_2$  is rotor current,

$\cos\theta_2$  is the power factor of rotor circuit.

The flux  $\phi$  produced by the stator is proportional to stator emf  $E_1$ .

i.e  $\phi \propto E_1$

We know that transformation ratio  $K$  is defined as the ratio of secondary voltage (rotor voltage) to that of primary voltage (stator voltage).

$$K = \frac{E_2}{E_1}$$

$$\text{or, } K = \frac{E_2}{\phi}$$

$$\text{or, } E_2 = \phi$$

Rotor current  $I_2$  is defined as the ratio of rotor induced emf under running condition,  $sE_2$  to total impedance,  $Z_2$  of rotor side,

$$\text{i.e } I_2 = \frac{sE_2}{Z_2}$$

and total impedance  $Z_2$  on rotor side is given by ,

$$Z_2 = \sqrt{R_2^2 + (sX_2)^2}$$

Putting this value in above equation we get,

$$I_2 = \frac{sE_2}{\sqrt{R_2^2 + (sX_2)^2}}$$

$s$  = slip of induction motor

We know that power factor is defined as ratio of resistance to that of impedance. The power factor of the rotor circuit is

$$\cos\theta_2 = \frac{R_2}{Z_2} = \frac{R_2}{\sqrt{R_2^2 + (sX_2)^2}}$$

Putting the value of flux  $\phi$ , rotor current  $I_2$ , power factor  $\cos\theta_2$  in the equation of torque we get,

$$T \propto E_2 \frac{sE_2}{\sqrt{R_2^2 + (sX_2)^2}} \times \frac{R_2}{\sqrt{R_2^2 + (sX_2)^2}}$$

Combining similar term we get,

$$T \propto sE_2^2 \frac{R_2}{\sqrt{R_2^2 + (sX_2)^2}}$$

Removing proportionality constant we get,

$$T = KsE_2^2 \frac{R_2}{\sqrt{R_2^2 + (sX_2)^2}}$$

*This constant*  $K = \frac{3}{2\pi n_s}$

Where,  $n_s$  is synchronous speed in r. p. s,  $n_s = N_s / 60$ . So, finally the equation of torque becomes,

$$T = sE_2^2 \times \frac{R_2}{R_2^2 + (sX_2)^2} \times \frac{3}{2\pi n_s} N - m$$

### Torque during starting condition

So, the equation of starting torque is easily obtained by simply putting the value of  $s = 1$  in the equation of torque of the three phase induction motor, because at the time of starting  $N=0$ .

So, slip  $s = \frac{N_s - N}{N_s}$  becomes 1

$$T = \frac{E_2^2 R_2}{R_2^2 + X_2^2} \times \frac{3}{2\pi n_s} N - m$$

## Maximum Torque Condition for Three-Phase Induction Motor

In the equation of torque,

$$T = \frac{sE_2^2 R_2}{R_2^2 + (sX_2)^2} \times \frac{3}{2\pi n_s}$$

The rotor resistance, rotor inductive reactance and synchronous speed of induction motor remain constant. The supply voltage to the [three phase induction motor](#) is usually rated and remains constant, so the stator emf also remains the constant. We define the transformation ratio as the ratio of rotor emf to that of stator emf. So if stator emf remains constant, then rotor emf also remains constant.

If we want to find the maximum value of some quantity, then we have to differentiate that quantity concerning some variable parameter and then put it equal to zero. In this case, we have to find the condition for maximum torque, so we have to differentiate torque concerning some variable quantity which is the slip,  $s$  in this case as all other parameters in the equation of torque remains constant.

So, for torque to be maximum

$$\frac{dT}{ds} = 0$$

$$T = K s E_2^2 \frac{R_2}{R_2^2 + (sX_2)^2}$$

Now differentiate the above equation by using division rule of differentiation. On differentiating and after putting the terms equal to zero we get,

$$s^2 = \frac{R_2^2}{X_2^2}$$

So, when slip  $s = R_2 / X_2$ , the torque will be maximum and this slip is called maximum slip  $S_m$  and it is defined as the ratio of rotor resistance to that of rotor reactance.

The equation of torque is

$$T = \frac{sE_2^2 R_2}{R_2^2 + (sX_2)^2}$$

The torque will be maximum when slip  $s = R_2 / X_2$

Substituting the value of this slip in above equation we get the maximum value of torque as,

$$T_{max} = K \frac{E_2^2}{2X_2} \quad N - m$$

In order to increase the starting torque, extra [resistance](#) should be added to the rotor circuit at start and cut out gradually as motor speeds up.

## Torque Slip Characteristic of an Induction Motor

The Torque Slip Characteristic is represented by a rectangular hyperbola. For the immediate value of the slip, the graph changes from one form to the other. Thus, it passes through the point of maximum torque when  $R_2 = sX_2$ . The maximum torque developed in an induction motor is called the Pull Out Torque or the Breakdown Torque. This torque is a measure of the short time overloading capability of the motor.

The torque slip characteristic curve is divided roughly into three regions. They are given below.

- Low slip region
- Medium slip region
- High slip region

The torque equation of the induction motor is given below.

$$T = \frac{k s R_2 E_{20}^2}{R_2^2 + (sX_{20})^2} \dots \dots \dots (1)$$

### LowSlipRegion

At the synchronous speed,  $s = 0$ , therefore, the torque is zero. When the speed is very near to synchronous speed. The slip is very low and  $(sX_{20})^2$  is negligible in comparison with  $R_2$ . Therefore,

$$T = \frac{k_1 s}{R_2}$$

If  $R_2$  is constant, the torque becomes

$$T = k_2 s \dots \dots (2)$$

When  $k_2 = k_1/R_2$

From the equation (1) shown above, it is clear that the torque is proportional to slip. Hence, in the normal working region of the motor, the value of the slip is small. The torque slip curve is a straight line.

### Medium Slip Region

As the slip increases, the speed of the motor decreases with the increase in load. The term  $(sX_2)^2$  becomes large. The term  $R_2$  may be neglected in comparison with the term  $(sX_2)^2$  and the torque equation becomes as shown below.

$$T = \frac{k_3 R_2}{s X_{20}^2} \dots \dots \dots (3)$$

At the standstill condition, the torque is inversely proportional to the slip.

### High Slip Region

Beyond the maximum torque point, the value of torque starts decreasing. As a result, the motor slows down and stops. At this stage, the overload protection must immediately disconnect the motor from the supply to prevent damage due to overheating of the motor.

The motor operates for the values of the slip between  $s = 0$  and  $s = s_M$ . Where,  $s_M$  is the value of the slip corresponding to the maximum torque. For a typical induction motor, the pull-out torque is 2 to 3 times the rated full load torque. The starting torque is about 1.5 times the rated full load torque.

The curve shown below shows the **Torque Slip Characteristic** of the Induction Motor.

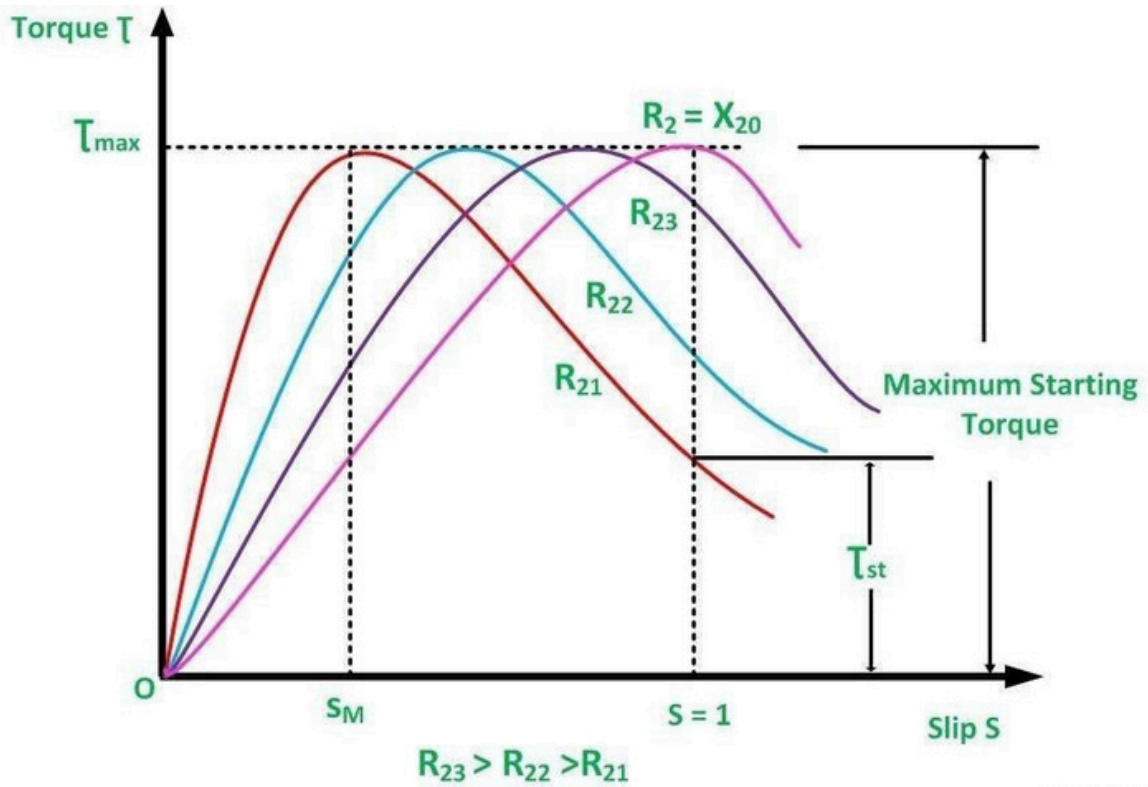

Circuit Globe

1. 7 Derive relation between full load torque and starting torque

### Relation Between Full-Load Torque & Maximum Torque

$$\text{➤ } T_f = \frac{K_1 \phi S_f E_2 R_2}{R_2^2 + (S_f X_2)^2}$$

$$\text{➤ } T_{\max} = \frac{K_1 \phi E_2}{2 X_2}$$

$$\text{➤ } \frac{T_f}{T_{\max}} = \frac{2 S_f X_2 R_2}{R_2^2 + (S_f X_2)^2} = \frac{2 S_f \frac{R_2}{X_2}}{\left(\frac{R_2}{X_2}\right)^2 + S_f^2}$$

$$\text{➤ } \frac{T_f}{T_{\max}} = \frac{2a S_f}{a^2 + S_f^2} \text{ if, } a = \frac{R_2}{X_2}$$

## Relation Between Starting Torque & Maximum Torque

$$\begin{aligned} \rightarrow T_{st} &= \frac{k_1 E_2^2 R_2}{R_2^2 + (X_2)^2}; \quad T_{\max} = \frac{k_1 E_2^2}{2 X_2} \\ \rightarrow \frac{T_{st}}{T_{\max}} &= \frac{2 X_2 R_2}{R_2^2 + X_2^2} = \frac{2 \frac{R_2}{X_2}}{\left(\frac{R_2}{X_2}\right)^2 + 1} \\ \rightarrow \frac{T_{st}}{T_{\max}} &= \frac{2a}{a^2 + 1} \quad \text{if,} \quad a = \frac{R_2}{X_2} \end{aligned}$$

**Math: B.L Thereja; Example: 34.15(a), 34.16, 34.24 (V.V.I)**

44

## Power Stages in an Induction Motor

Stator iron loss (consisting of eddy and hysteresis losses) depends on the supply frequency and the flux density in the iron core. It is practically constant. The iron loss of the rotor is, however, negligible because frequency of rotor currents under normal running conditions is always small. Total rotor Cu loss =  $3 I_2^2 R$

Different stages of power development in an induction motor are as under :

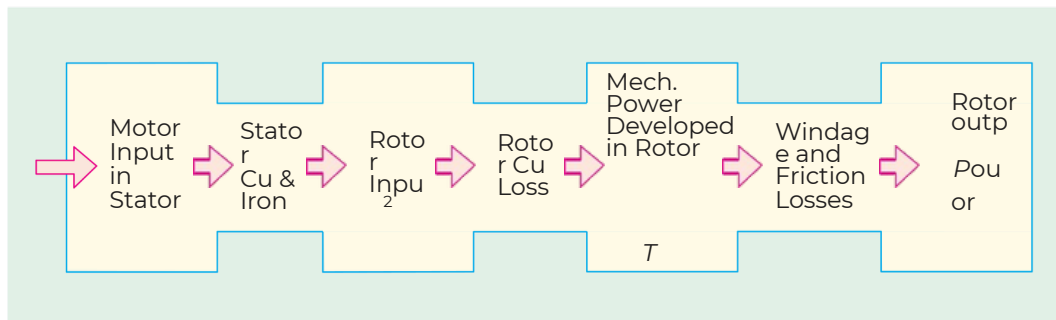

## Torque Motor Developed by an Induction

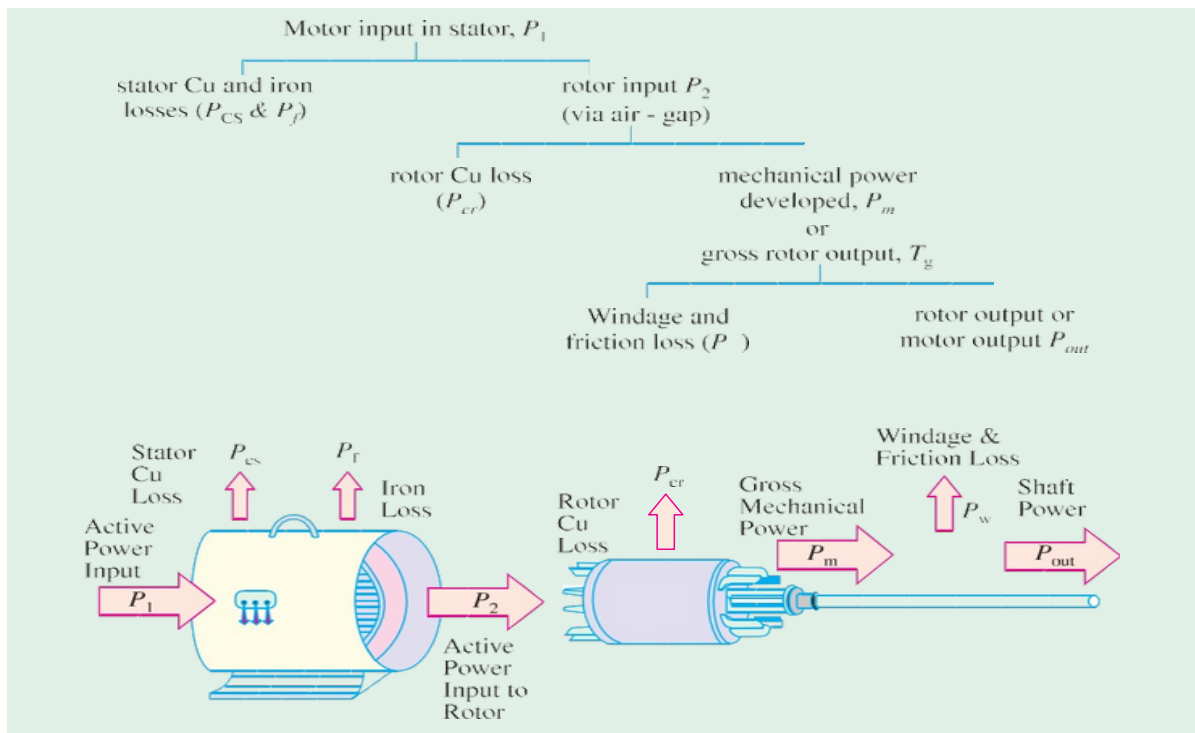

$$T_g = \frac{P_m}{\omega} = \frac{P_m}{2\pi N} \quad \dots \text{ in terms of rotor output}$$

The shaft torque  $T_{sh}$  is due to output power  $P_{out}$  which is less than  $P_m$  because of rotor friction and windage losses.

$$\therefore T_{sh} = P_{out} / \omega = P_{out} / 2\pi N$$

The difference between  $T_g$  and  $T_{sh}$  equals the torque lost due to friction and windage loss in the motor.

In the above expressions,  $N$  and  $N_s$  are in r.p.s. However, if they are in r.p.m., the above expressions for motor torque become

$$\begin{aligned} T_g &= \frac{P_2}{2\pi \frac{N_s}{60}} = \frac{60}{2\pi} \cdot \frac{P_2}{N_s} = 9.55 \frac{P_2}{N_s} \text{ N-m} \\ &= \frac{60}{2\pi} \cdot \frac{P_m}{N} = 9.55 \frac{P_m}{N} \text{ N-m} \\ T_{sh} &= \frac{P_{out}}{2\pi N / 60} = \frac{60}{2\pi} \cdot \frac{P_{out}}{N} = 9.55 \frac{P_{out}}{N} \text{ N-m} \end{aligned}$$

Stator input  $P_1 =$  stator output + stator losses  
The stator output is transferred entirely inductively to the rotor circuit.

CS Scanned with CamScanner

## Torque, Mechanical Power and Rotor Output

Stator input  $P_1 =$  stator output + stator losses

The stator output is transferred entirely inductively to the

rotor circuit. Obviously, rotor input  $P_2 =$  stator output

Rotor gross output,  $P_m =$  rotor input  $P_2 -$  rotor Cu losses

This rotor output is converted into mechanical energy and gives

rise to gross torque  $T_g$ . Out of this gross torque developed,

some is lost due to windage and friction losses in the rotor and

the rest appears as the useful or shaft torque  $T_{sh}$

Let  $N$  r.p.s. be the actual speed of the

rotor and if  $T_g$  is in N-m, then

$T_g \times 2\pi N =$  rotor gross output in watts,  $P_m$

$T_g =$  rotor gross output in watts,  $P_m / 2\pi N$ ------(1)

If there were no Cu losses in the rotor, then rotor output will equal rotor input and the rotor will run at synchronous speed.

$$\therefore T_g = \frac{\text{rotor input } P_2}{2\pi N_s} \quad \dots$$

From and , we get,

$$\text{Rotor gross output } P_m = T_g \omega = T_g \times 2\pi N$$

$$\text{Rotor input } P_2 = T_g \omega_s = T_g \times 2\pi N_s \quad \dots$$

The difference of two equals rotor Cu loss.

$$\therefore \text{rotor Cu loss} = P_2 - P_m = T_g \times 2\pi (N_s - N) \quad \dots$$

$$\text{From and , } \frac{\text{rotor Cu loss}}{\text{rotor input}} = \frac{N_s - N}{N_s} = s$$

$$\therefore \text{rotor Cu loss} = s \times \text{rotor input} = s \times \text{power across air-gap} = s P_2 \quad \dots$$

$$\text{Also, rotor input} = \text{rotor Cu loss}/s$$

$$\text{Rotor gross output, } P_m = \text{input } P_2 - \text{rotor Cu loss} = \text{input} - s \times \text{rotor input} \\ = (1-s) \text{ input } P_2 \quad \dots$$

$$\therefore \text{rotor gross output } P_m = (1-s) \text{ rotor input } P_2$$

$$\text{or } \frac{\text{rotor gross output, } P_m}{\text{rotor input, } P_2} = 1-s = \frac{N}{N_s}; \quad \frac{P_m}{P_2} = \frac{N}{N_s}$$

$$\therefore \text{rotor efficiency} = \frac{N}{N_s} \quad \text{Also, } \frac{\text{rotor Cu loss}}{\text{rotor gross output}} = \frac{s}{1-s}$$

If some power  $P_2$  is delivered to a rotor, then a part  $sP_2$  is lost in the rotor itself as copper loss (and appears as heat) and the remaining  $(1-s)P_2$  appears as gross mechanical power  $P_m$  (including friction and windage losses).

$$\therefore P : P_m : P_2 :: 1 : (1-s) : s \quad \text{or } P : P_2 : P_m :: 1 : (1-s) : s$$

The value of gross torque in kg-m is given by

$$T_g = \frac{\text{rotor gross output in watts}}{9.81 \times 2\pi N} \text{ kg-m.} = \frac{P_m}{9.81 \times 2\pi N} \text{ kg-m}$$

## 1. 9 Explain and state Methods of starting and different types of starters.

Methods of Starting Squirrel Cage I.M There are basic four methods of starting the squirrel cage induction motor using

- (a) Direct online starters
- (b) Stator Resistor (or reactor) Starters
- (c) Auto-transformer Starters
- (d) Star-Delta Starters

### DOL Starter Working Principle

The working principle of a **DOL starter** begins with the connection to the 3- phase main with the motor. The control circuit is connected to any two phases and energized from them only. When we press the start button, the current flows through contactor coil (magnetizing coil) and control circuit also. The current energises the contactor coil and leads to close the contacts, and hence 3-phase supply becomes

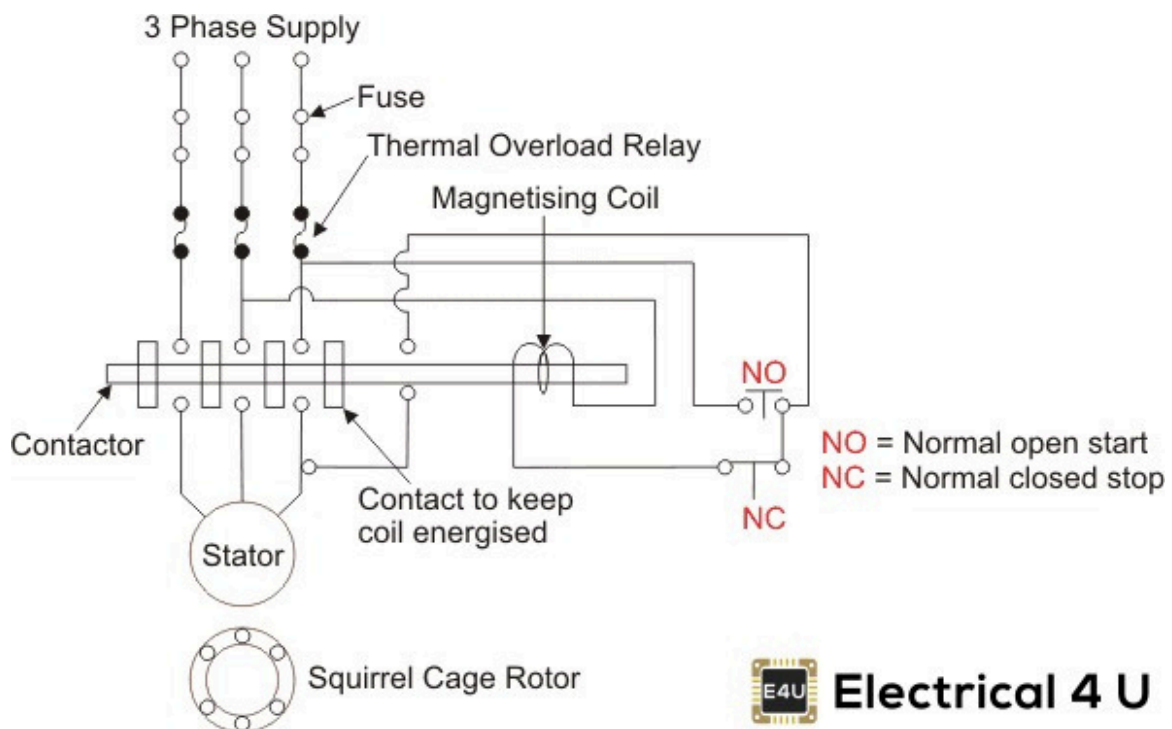

available to the motor. The control circuit for a DOL Starter is shown below.

If we press the stop button, the current through the contact becomes discontinued, hence supply to the motor will not be available, and the similar thing will happen when the overload relay operates. Since the supply of motor breaks, the machine will come to rest. The contactor coil (Magnetizing Coil) gets supply even though we release start button because when we release start button, it will get supply from the primary contacts as illustrated in the diagram of the **Direct Online Starter**.

## DOL Starter Applications

The applications of DOL starters are primarily motors where a high inrush current does not cause excessive voltage drop in the supply circuit (or where this high voltage drop is acceptable).

Direct on line starters are commonly used to start small water pumps, conveyor belts, fans, and compressors. In the case of an asynchronous motor (such as the 3-phase squirrel-cage motor) the motor will draw a high starting current until it has run up to full speed.

## Auto-transformers

[Auto-transformers](#) are also known as auto-starters. They can be used for both star connected or delta connected [squirrel cage motors](#). It is basically a three phase step down transformer with different taps provided that permit the user to start the motor at, say, 50%, 65% or 80% of line voltage. With auto-transformer starting, the current drawn from supply line is always less than the motor current by an amount equal to the [transformation ratio](#). For [example](#), when a motor is started on a

65% tap, the applied voltage to the motor will be 65% of the line voltage and the applied current will be 65% of the line voltage

starting value, while the line current will be 65% of 65% (i.e. 42%) of the line voltage starting value. This difference between the line current and the motor current is due to transformer action. The internal connections of an auto- starter are as shown in the figure. At starting, switch is at "start" position, and a reduced voltage (which is selected using a tap) is applied across the stator. When the motor gathers an appropriate speed, say upto 80% of its rated speed, the auto-transformer automatically gets disconnected from the circuit as the switch goes to "run" position.

The switch changing the connection from start to run position may be air-break (small motors) or oil-immersed (large motors) type. There are also provisions for no-voltage and overload, with time delay circuits on an auto starter.

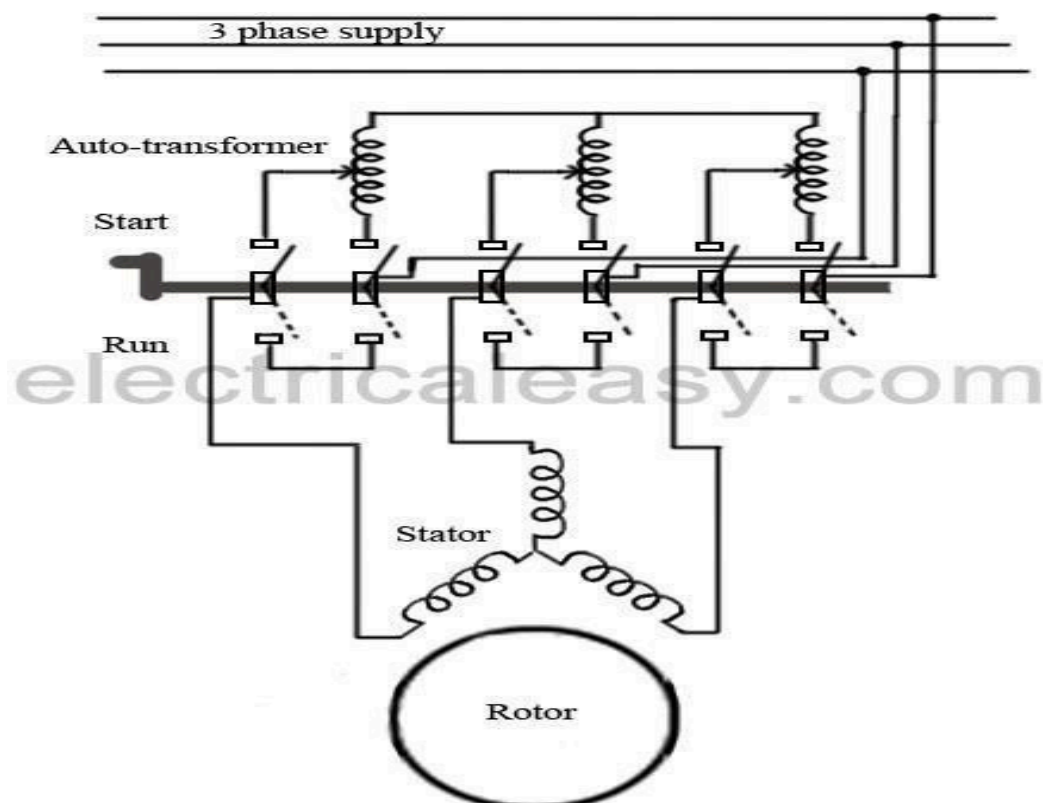

## Starting of slip-ring motors

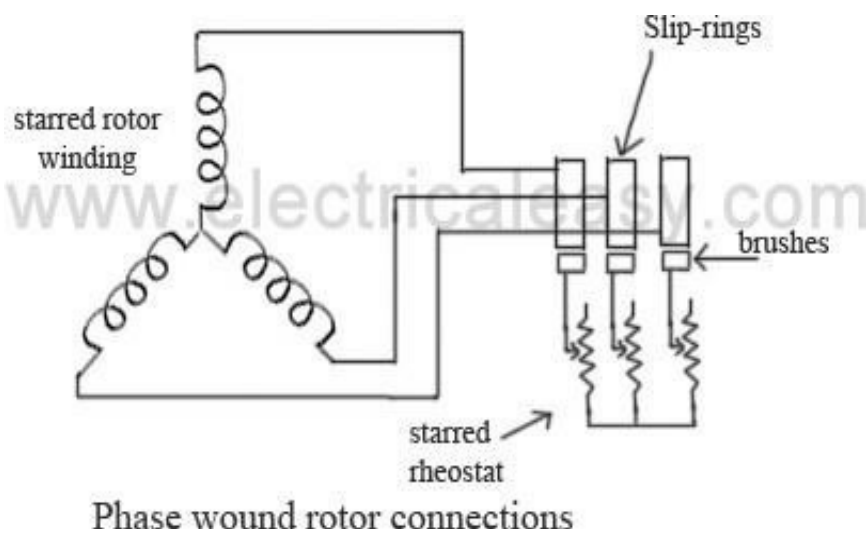

[Slip-ring motors](#) are started with full line voltage, as external resistance can be easily added in the rotor circuit with the help of slip-rings. A star connected rheostat is connected in series with the rotor via slip-rings as shown in the fig. Introducing resistance in rotor current will decrease the starting current in rotor (and, hence, in stator). Also, it improves power factor and the torque is increased. The connected rheostat may be hand-operated or automatic.

As, introduction of additional resistance in rotor improves the starting torque, slip-ring motors can be started on load.

The external resistance introduced is only for starting purposes, and is gradually cut out as the motor gathers the speed.

## Star Delta Starter

A star delta starter will start a motor with a star connected stator winding. When motor reaches about 80% of its full load speed, it will begin to run in a delta connected stator winding.

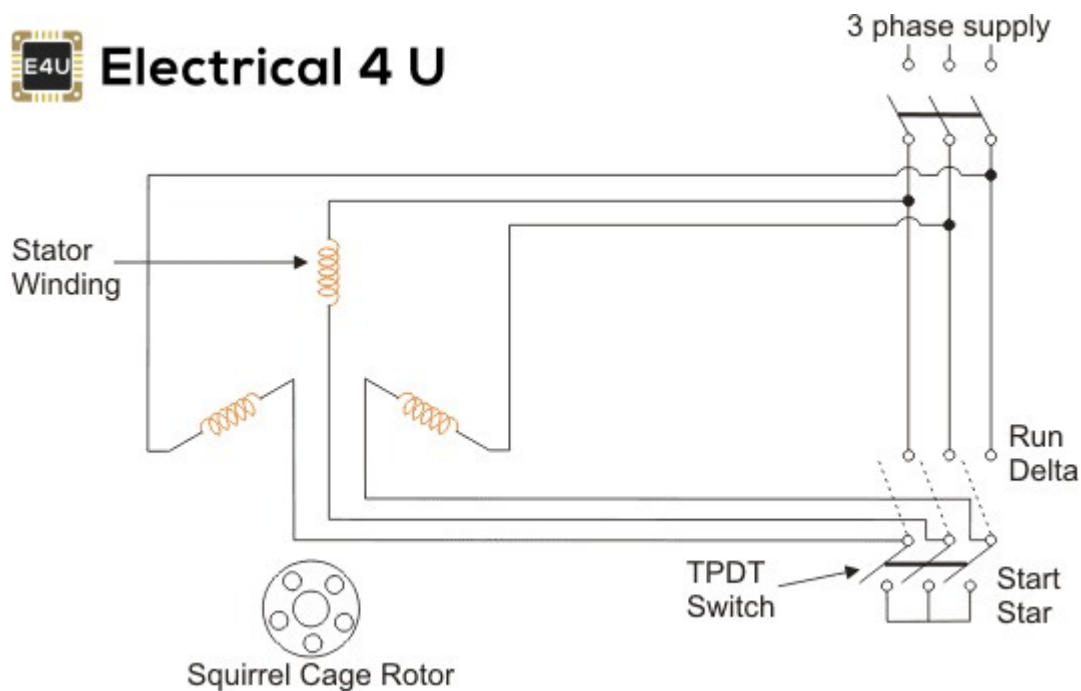

A star delta starter is a type of reduced voltage starter. We use it to reduce the starting current of the motor without using any external device or apparatus. This is a big advantage of a star delta starter, as it typically has around 1/3 of the inrush current compared to a \_\_\_\_\_

DOL starter. The starter mainly consists of a TPDP switch which stands for Tripple Pole Double Throw switch. This switch changes stator winding from star to delta. During starting condition stator winding is connected in the form of a star. Now we shall see how a star delta starter reduces the starting current of a three-

phase induction motor.

For that let us consider,

$V_L$  = Supply Line Voltage,  $I_{LS}$  = Supply Line Current and,  $I_{PS}$  = Winding Current per Phase and  $Z$  = Impedance per phase winding at stand still condition.

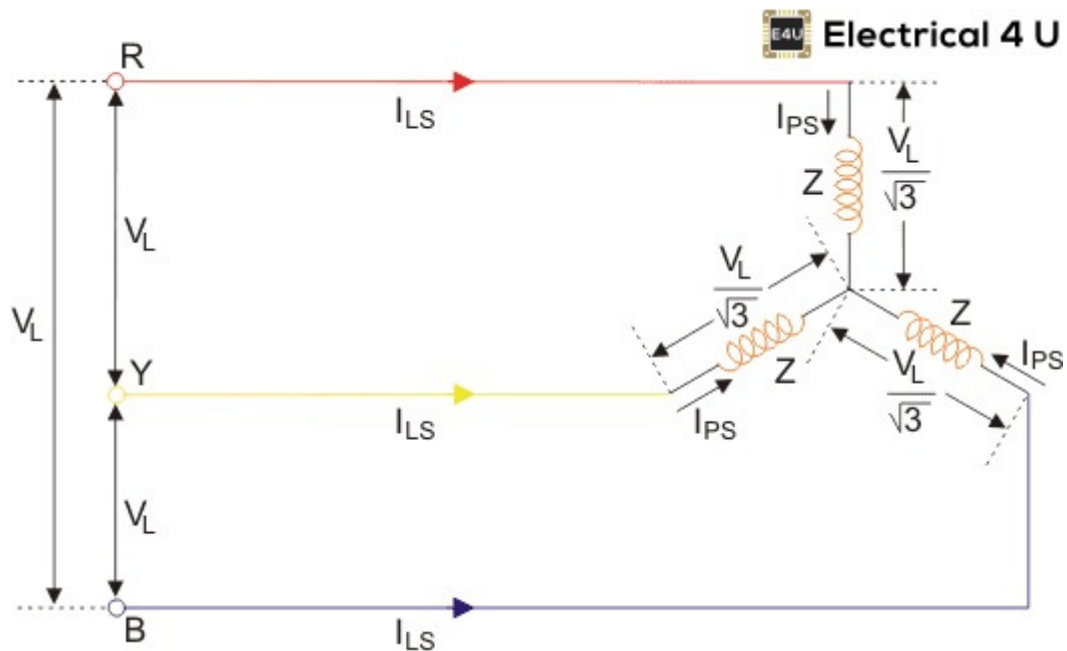

As the winding is star connected, the winding current per phase ( $I_{PS}$ ) equals to supply line current ( $I_{LS}$ ).

$$I_{PS} = I_{LS}$$

As the winding is star connected, the voltage across each phase of the winding is

$$\frac{V_L}{\sqrt{3}}$$

Hence, the winding current per phase is

$$I_{PS} = \frac{V_L}{\sqrt{3}Z}$$

Since here, the winding current per phase ( $I_{PS}$ ) equals to the supply line current ( $I_{LS}$ ), we can write,

$$I_{PS} = \frac{V_L}{\sqrt{3}Z} \Leftrightarrow I_{LS} = \frac{V_L}{\sqrt{3}Z}$$

Now, let us consider the situation where the motor gets started with delta connected stator winding from same three phase supply points,

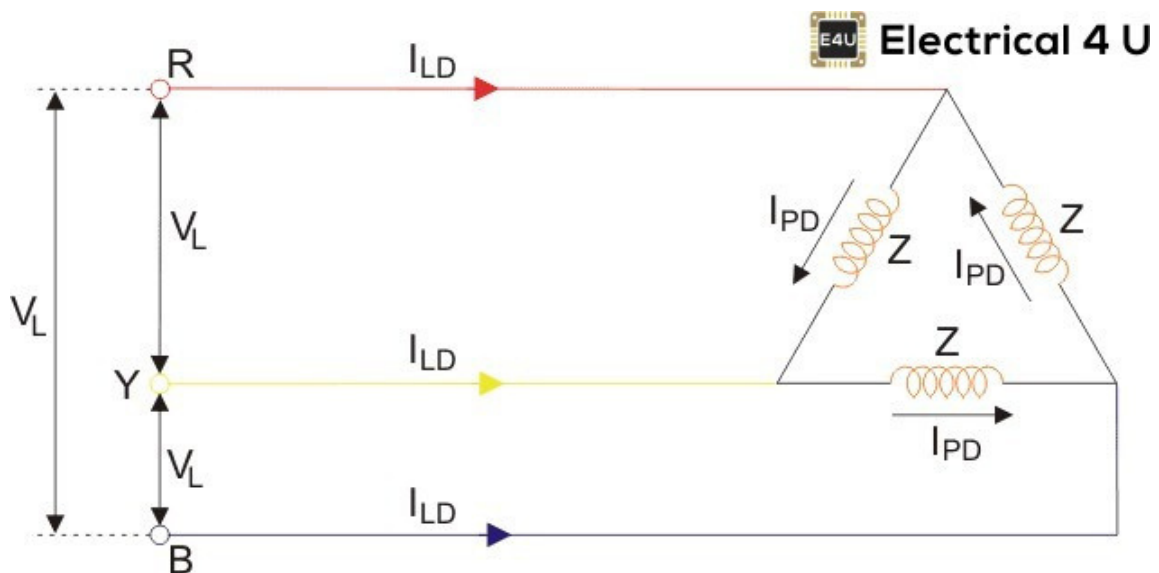

Here,  $I_{LD}$  = Supply Line Current and,  $I_{PD}$  = Winding Current per Phase and  $Z$  = Impedance per phase winding at stand still condition.

As the winding is delta connected, supply line current ( $I_{LD}$ ) is root three times of the winding current per phase ( $I_{PD}$ )

$$I_{LD} = \sqrt{3} I_{PD}$$

As the winding is delta connected, the voltage across each phase of the winding is

$$V_L$$

Hence, the winding current per phase is

$$I_{PD} = \frac{V_L}{Z}$$

Now, we can write,

$$I_{LD} = \sqrt{3} I_{PD} = \frac{\sqrt{3} V_L}{Z}$$

Now, by comparing supply line currents drawn by an induction motor with star and delta connected winding, we get

$$\frac{I_{LD}}{I_{LS}} = \frac{\frac{\sqrt{3} V_L}{Z}}{\frac{V_L}{\sqrt{3} Z}} = 3 \Rightarrow I_{LS} = \frac{1}{3} I_{LD}$$

Thus we can say that the starting current from the mains in case of star delta is one-third of direct switching in the delta. Again, we know that the starting torque of an induction motor is proportional to the square of the voltage applied to the winding per phase.

$$\frac{\text{Starting torque in star connected stator winding motor}}{\text{Starting torque in delta connected stator winding motor}}$$

$$= \frac{\left(\frac{V_L}{\sqrt{3}}\right)^2}{V_L^2} = \frac{1}{3}$$

The equation shows that **star delta starter** reduces the starting torque to one-

third of that produced by DOL starter. The star-delta starter is equivalent to an autotransformer with a 57.7% tapping.

1.10 Explain speed control by Voltage Control, Rotor resistance control, pole changing, frequency control methods.

## Speed Control from Stator Side

### V / f Control or Frequency Control

Whenever three phase supply is given to three phase induction motor rotating magnetic field is produced which rotates at synchronous speed given by

$$N_s = \frac{120f}{P}$$

In three phase induction motor emf is induced by induction similar to that of transformer which is given by

$$E \text{ or } V = 4.44\phi K.T.f \text{ or } \phi = \frac{V}{4.44KTf}$$

Where, K is the winding constant, T is the number of turns per phase and f is frequency. Now if we change frequency synchronous speed changes but with decrease in frequency flux will increase and this change in value of flux causes saturation of rotor and stator cores which will further cause increase in no load current of the motor . So, its important to maintain flux,  $\phi$  constant and it is only possible if we change voltage. i.e if we decrease frequency flux increases but at the same time if we decrease voltage flux will also decrease causing no change in flux and hence it remains constant. So, here we are keeping the ratio of V/f as constant. Hence its name is V/ f method. For controlling the speed of three phase induction motor by V/f method we have to supply variable voltage and frequency which is easily obtained by using converter and inverter set.

## Controlling Supply Voltage

The torque produced by running three phase induction motor is given by

$$T \propto \frac{sE_2^2 R_2}{R_2^2 + (sX_2)^2}$$

In low slip region  $(sX_2)^2$  is very very small as compared to  $R_2$ . So, it can be neglected. So torque becomes

$$T \propto \frac{sE_2^2}{R_2}$$

We know that rotor induced emf  $E_2$  V. So,  $T \propto sV^2$ .

The equation above clears that if we decrease supply voltage torque will also decrease. But for supplying the same load, the torque must remain the same, and it is only possible if we increase the slip and if the slip increases the motor will run at a reduced speed. This method of speed control is rarely used because a small change in speed requires a large reduction in voltage, and hence the [current](#) drawn by motor increases, which cause overheating of the [induction motor](#).

## Changing the number of stator poles

The stator poles can be changed by two methods

- Multiple stator winding method.
- Poleamplitude modulationmethod(PAM)

### Multiple Stator Winding Method

In this method of speed control of three phase induction motor, we provide two separate windings in the stator. These two stator windings are electrically

isolated from each other and are wound for two different numbers of poles. Using a switching arrangement, at a time, supply is given to one winding only and hence speed control is possible. Disadvantages of this method are that the smooth speed control is not possible. This method is more costly and less efficient as two different stator windings are required. This method of speed control can only be applied to [squirrel cage motor](#). \_\_\_\_\_

### Pole Amplitude Modulation Method (PAM)

In this method of speed control of three phase induction motor the original sinusoidal mmf wave is modulated by another sinusoidal mmf wave having the different number of poles.

## Speed Control from Rotor Side

### Adding External Resistance on Rotor Side

In this method of speed control of three phase induction motor external resistance are added on rotor side. The equation of torque for three phase induction motor is

$$T \propto \frac{sE_2^2 R_2}{R_2^2 + (sX_2)^2}$$

The three-phase induction motor operates in a low slip region. In low slip region term  $(sX)^2$  becomes very very small as compared to  $R_2$ . So, it can be neglected. and also  $E_2$  is constant. So the equation of torque after simplification becomes,

$$T \propto \frac{s}{R_2}$$

Now if we increase rotor resistance,  $R_2$  torque decreases but to supply the same load torque must remain constant. So, we increase slip, which will further result in the decrease in rotor speed. Thus by adding additional resistance in the rotor circuit, we can decrease the speed of the three-phase induction motor. The main advantage of this method is that with an addition of external resistance starting torque increases but this method of speed control of three phase induction motor also suffers from some disadvantages :

- The speed above the normal value is not possible.
- Large speed change requires a large value of resistance, and if such large value of resistance is added in the circuit, it will cause large copper loss and hence reduction in efficiency.
- Presence of resistance causes more losses.
- This method cannot be used for squirrel cage induction motor.

## 1. 11 Describe plugging applicable to three phase induction motor.

There are generally three types of electrical braking for motors: [Regenerative braking](#),

[Dynamic braking](#) , and

Plugging. Of the three methods, plugging provides the fastest stop, but it can be harsh on both the electrical and mechanical components. Because of this, it's the least commonly used method of braking, but it is appropriate for some applications.

Plugging — sometimes referred to as “reverse current braking” — is possible on both DC motors and AC induction motors. For DC motors, plugging is

achieved by reversing the polarity of the armature voltage. When this happens, the back EMF voltage no longer opposes the supply voltage. Instead, the back EMF and the supply voltage work in the same direction, opposing the motor's rotation and causing it to come to a near-instant stop. The reverse current produced by the combined supply voltage and back EMF is extremely high, so resistance is placed in the circuit to limit the current.

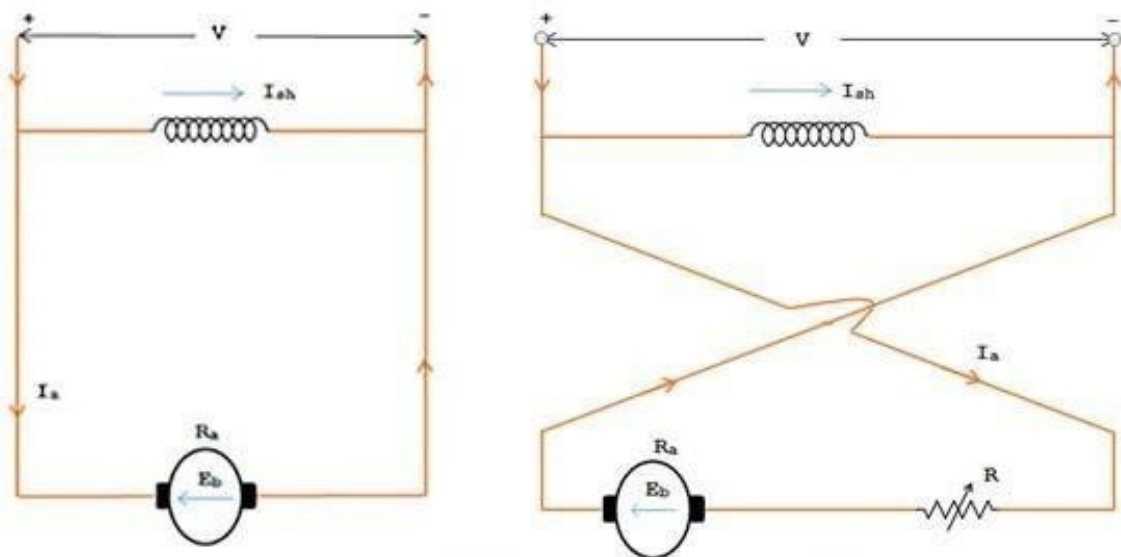

For AC induction motors, the stator voltage is reversed by interchanging any two of the supply leads. The field then rotates in the opposite direction and the motor's slip (the difference between the speed of the stator's rotating magnetic field and the speed of the rotor) becomes greater than unity ( $s > 1$ ). In other words, the rotor spins faster than the rotating magnetic field in the stator. Torque is developed in the opposite direction of the motor's rotation, which produces a strong braking effect.

When the motor speed reaches zero, if it is not disconnected from the supply, it will begin to reverse, or rotate in the

opposite direction. In some applications, reversal of the motor's direction is the goal. But when plugging is

used to *brake* the motor, a zero-speed switch or plugging contactor is used to disconnect the motor from the supply when its speed reaches zero.

One of the potential problems with plugging as a braking method (especially when the braking time is short) is that it can be difficult to brake the motor at exactly zero speed. Another drawback to plugging is that it can induce high mechanical shock loads on the motor and connected equipment, due to the abrupt stop that it causes. Plugging is also a very inefficient method of stopping and, therefore, generates significant heat.

Despite these drawbacks, plugging is used in equipment such as elevators, cranes, presses, and mills, where a rapid stop of the motor (with or without reversal) is required.

### 1.13 Explain principle of Induction Generator and state its applications.

Induction machines are sometimes used as a generator. These are known as **induction generators** or **asynchronous generators**. So under what conditions will an induction machine will behave as an induction generator?

An induction machine will behave as an induction generator when:

Slip becomes negative due to this the rotor current and rotor emf attains negative value.

The prime mover torque becomes opposite to electric torque.

## How induction generators work?

- Consider, an AC supply is connected to the stator terminals of an induction machine. Rotating magnetic field produced in the stator pulls the rotor to run behind it (the machine is acting as a motor). Now, if the rotor is accelerated to the synchronous speed by means of a prime mover, the slip will be zero and hence the net torque will be zero. The rotor current will become zero when the rotor is running at synchronous speed. If the rotor is made to rotate at a speed more than the synchronous speed, the slip becomes negative. A rotor current is generated in the opposite direction, due to the rotor conductors cutting stator magnetic field. This generated rotor current produces a rotating magnetic field in the rotor which pushes (forces in opposite way) onto the stator field. This causes a stator voltage which pushes current flowing out of the stator winding against the applied voltage. Thus, the machine is now **working as an induction generator (asynchronous generator)**.

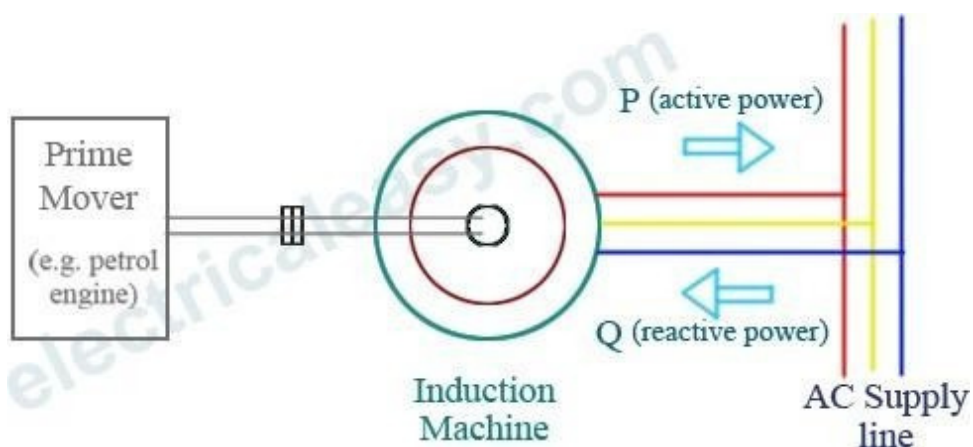

Induction generator is not a self-excited machine. Therefore, when running as a generator, the machine takes reactive power from the AC power line and supplies active power back into the line. Reactive power is needed for producing rotating magnetic field. The active power supplied back in the line is proportional to slip above the synchronous speed.

### Self- excited induction generator

It is clear that, an induction machine needs reactive power for excitation, regardless whether it is operating as a generator or a motor. When an induction generator is connected to a grid, it takes reactive power from the grid. But what if we want to use an induction generator to supply a load without using an external source (e.g. grid)?

A capacitor bank can be connected across the stator terminals to supply reactive power to the machine as well as to the load. When the rotor is rotated at an enough speed, a small voltage is generated across the stator terminals due to residual magnetism. Due to this small generated voltage, capacitor current is produced which provides further reactive power for magnetization.

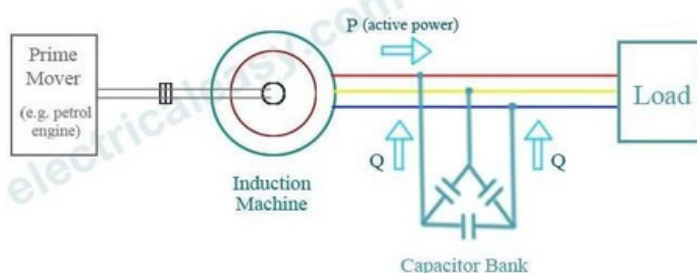

## Application of Induction Generator

Let us discuss **application of induction generator**: We have two types of **induction generator** let us discuss the application of each type of generator separately: Externally excited generators are widely used for regenerative braking of hoists driven by the **three phase induction motors**. Self-excited generators are used in the wind mills. Thus this type of generator helps in ~~converting the~~ unconventional sources of energy into **electrical energy**. Now let us discuss some disadvantages of externally excited generator:

- The efficiency of the externally excited generator is not so good.
- We cannot use externally excited generator at lagging **power factor** which major drawback of this type of generator.
- The amount of reactive power used to run these types of generator required is quite large.

## Advantages of Induction Generators

- It has robust construction requiring less maintenance
- Relatively cheaper
- Small size per kW output power (i.e. high energy density)
- It runs in parallel without hunting
- No synchronization to the supply line is required like a **synchronous generator**

## Disadvantages of Induction Generators

- It cannot generate reactive voltamperes. It requires reactive voltamperes from the supply line to furnish its excitation.